



Outdoor 15 PSI Low Pressure Steam Boilers Power Burner Fired

PRODUCT DESCRIPTION

Rite Power Burner Fired Low Pressure Steam Boilers have been providing our valued customers with high quality steam safely and reliably for over forty years. From autoclaves to humidifiers, bakeries to breweries – these heavy duty watertube steamers are available in 47 different models, ranging from 480 – 12,499 MBH input (11 – 300 Boiler Horsepower) for the widest selection possible.

So simple to maintain and operate, Rite Steam Boilers feature **complete waterside access** so that virtually all scale and mud deposits can be seen and mechanically cleaned during a single scheduled maintenance shutdown. The result – **Better fuel-to-steam efficiency and lower operating cost over the life of your boiler investment.** Consider a few of our other standard features: Rite's floating heads that eliminate pressure vessel cracks and broken welds caused by thermal stress cycling (backed by our **25 Year Thermal Shock Warranty**), Rite's "superheated" drying tubes that regularly boost steam quality at the nozzle into the 99%+ range, Rite's bolted/gasketed headplates that eliminate any possibility of hydraulic explosion in the event that safety devices fail – and you have a better boiler by design.

RITE POWER BURNER FEATURES

Rite Power Burner Fired Low Pressure Steam Boilers must be specified when: Low NOx emissions are required or fuels other than natural gas will be used. While Power Burners are more expensive and use more electrical power than atmospheric, they do have one advantage: by controlling the amount of air they use for combustion, Power Burners achieve higher combustion efficiencies than atmospheric – especially at less than full fire rate.

RITE POWER BURNER FIRED BOILERS vs. "FORCED DRAFT BOILERS"

Both use Power Burners to combust the fuel, but the similarities end there. Forced draft boilers require larger fan motors to "push" the products of combustion out a sealed combustion chamber and into a positive pressure stack. Should a leak develop in the combustion chamber or stack of a forced draft boiler – potentially toxic flue gasses could escape into the boiler room.

Rite Power Burner Fired Boilers use smaller fan motors to combust the fuel only. All Rite Boilers are designed to operate with negative pressure combustion chambers and stacks, which means flue gasses are **safely** under negative draft conditions from the time the fuel is burned until they exit the stack.





Outdoor 15 PSI Low Pressure Steam Boilers Models & Ratings / Power Burner Fired

STACK / DRAFT REQUIREMENTS

- UL listed for use with Type B Vent when power burner is for natural or L.P. gas fired only.
- Type 316 stainless steel lined stack is required when equipped with #2 oil or combination gas & #2 oil burner.
- Recommended stack height for natural or L.P. gas fired burners is 6 feet
- Recommended stack height for #2 oil or combination gas & #2 oil fired boilers is 10-12 ft.
- The stack should be supported independently of the boiler
- A minimally restrictive rain cap with integral down draft protection (supplied by others) is required.
- Proper draft range is between -.05" to -.09" water column.

AIR REQUIREMENTS

- Adequate Combustion/Ventilation Air is vital for safe, efficient operation. Refer to the latest edition of the Uniform Mechanical Code or consult your local Building and Safety Department for specific requirements.

ELECTRICAL REQUIREMENTS

- A single point 1 or 3 phase supply is required to the burner panel. See separate Burner Price Lists for standard electrical power requirements.
- Separate electrical supply may be required to operate boiler feed pump.

NATURAL GAS SUPPLY REQUIREMENTS

- Refer to burner specification sheet or quote.

#2 OIL SUPPLY REQUIREMENT

- Supply to oil pump: minimum gravity flow to maximum 3 psi.

ELEVATION DERATION

Ratings given below are for elevations up to 2000 feet. Ratings should be reduced at the rate of 4% for every 1000 feet above 2000 feet.

FEEDWATER SYSTEMS & BLOWDOWN TANKS

Rite manufactures a complete line of Condensate Return Feedwater Tanks and Blowdown Tanks for our Steam Boilers shown below.

BOILER MODEL	Input MBH	Nominal Output		E.D.R.	Heating Surface Sq. Ft.	Flooded Water Content Gallons	Normal Water Level Content Gallons	Pounds of Steam per Hour @ 212 F	Nominal Shipping Weight (lbs)
		MBH	Boiler Horsepower						
W48 S *	480	384	11	1600	49	35	25	395	1500
W55 S *	550	440	13	1833	56	40	27	453	1650
W63 S *	630	506	15	2108	63	45	29	519	1800
W76 S *	760	608	18	2533	75	54	32	626	1950
W85 S *	850	680	20	2833	88	61	49	700	2325
W90 S *	900	720	21	3000	88	64	49	742	2325
W105 S *	1050	840	25	3500	101	76	52	865	2750
W120 S *	1200	960	28	4000	115	85	55	989	3125
W135 S *	1350	1080	32	4500	131	97	58	1113	3450
W150 S *	1500	1200	35	5000	145	105	60	1236	3800
W165 S *	1650	1320	39	5500	159	118	64	1360	4100
W180 S *	1800	1440	43	6000	174	130	68	1484	4400
W200 S *	2000	1600	47	6667	192	140	74	1649	4800
WA150 S *	1500	1200	35	5000	160	120	74	1236	3850
WA165 S *	1650	1320	39	5500	168	128	78	1360	4050
WA180 S *	1800	1440	43	6000	190	140	81	1484	4300
WA200 S *	2000	1600	47	6667	205	150	84	1649	4550
W225 S *	2250	1800	53	7500	230	162	87	1855	4800
W250 S *	2500	2000	59	8333	252	180	92	2061	5100
W275 S *	2750	2200	65	9167	273	196	96	2267	5400
W300 S *	3000	2400	71	10000	295	215	100	2473	5700
W325 S *	3250	2600	77	10833	318	234	105	2679	6000
W350 S *	3500	2800	83	11667	340	251	110	2885	6300
W375 S *	3750	3000	89	12500	362	268	115	3091	6600
W400 S *	4000	3200	95	13333	383	287	125	3297	8600
W425 S *	4250	3400	101	14167	405	304	129	3504	9000
W450 S *	4500	3600	107	15000	428	322	132	3710	9350
W475 S *	4750	3800	113	15833	450	337	135	3916	9700
W500 S *	5000	4000	119	16667	473	352	140	4122	10100
W550 S *	5500	4400	131	18333	526	370	147	4534	10800
W600 S *	6000	4800	143	20000	574	387	158	4946	11750
WA650 S *	6500	5200	155	21667	622	405	166	5359	12500
WA700 S *	7000	5600	167	23333	670	430	174	5731	13200
WA750 S *	7500	6000	180	25000	722	455	179	6183	13900
WA400 S *	4000	3200	95	13333	390	300	165	3297	9300
WA450 S *	4500	3600	107	15000	440	325	174	3710	10125
WA500 S *	5000	4000	119	1667	486	345	183	4122	10950
WA550 S *	5500	4400	131	18333	535	380	199	4534	12250
WA600 S *	6000	4800	143	20000	584	405	207	4946	13000
W650 S *	6500	5200	155	21667	632	425	215	5359	13800
W700 S *	7000	5600	167	23333	680	450	223	5771	14600
W750 S *	7500	6000	180	25000	730	470	232	6183	15400
W840 S *	8400	6700	200	27917	800	490	399	6935	20000
W940 S *	9400	7500	225	31250	900	515	419	7250	20800
W1050 S *	10500	8400	250	35000	1000	540	439	8657	21600
W1150 S * 1	1500	9200	275	38333	1100	565	459	9481	22400
W1250 S *	12499	9999	300	41662	1200	590	480	10300	23000

* Add **G** for natural gas or propane, **O** for #2 oil or **GO** for combination gas & #2 oil.



Outdoor 15 PSI Low Pressure Steam Boilers Models & Dimensions / Power Burner Fired

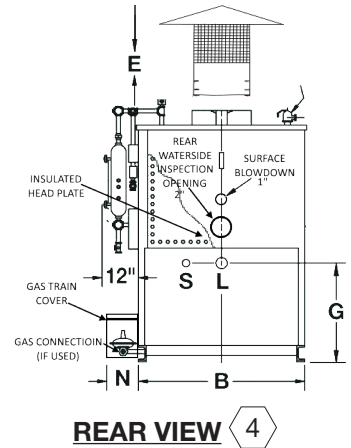
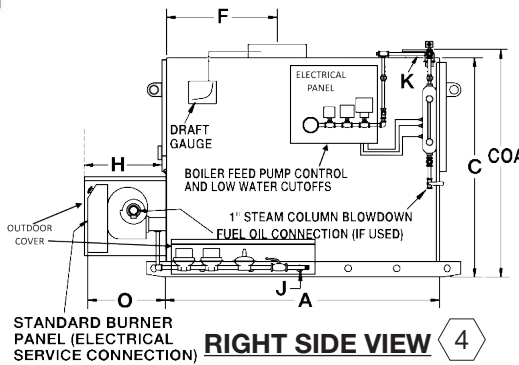
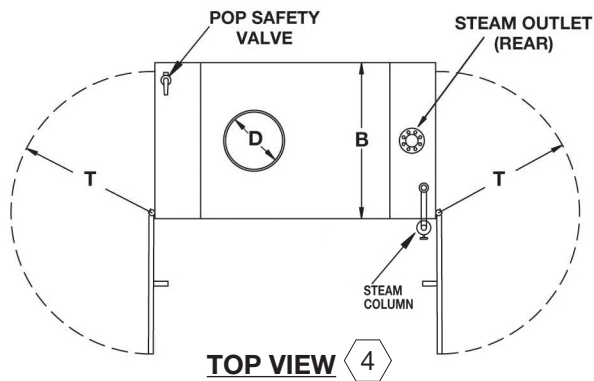

- DIMENSIONS ARE IN INCHES - SUBJECT TO PRODUCTION TOLERANCES AND CHANGE WITHOUT NOTICE. CERTIFIED DIMENSIONS AVAILABLE UPON REQUEST.
- BOILERS APPROVED FOR INSTALLATION ON NON-COMBUSTIBLE FLOORS ONLY.

② May vary - sizes shown are for UL gas trains at standard supply pressures. Gas connections are male NPT pipe thread. All other threaded connections are female NPT.
 ③ Flanges are ANSI 150 lb SA-105 flat face. Models A150S* - 375S*: 6" FLG STD. for U.S. locations, 5" FLG for Canadian locations.
 ④ Standard right hand construction shown illustrated above. Left hand construction available at no extra charge.

BOILER MODEL	A	B	C	COA	D	F	G	H	②J	③K	L	N	O	S	T
	Length Jacket	Width Jacket	Height Flush	Height Overall	Stack Dia.	Stack Conn.		Tube Maint.	Gas Conn.	Steam Supply	Feed Water	Side Space	Power Burner	Blow Down	Head Swing
W48 S*	47	33	65	69	10	17	32	40	1	3 FL	1 1/4	10	26	1	20
W55 S*	52	33	65	69	10	18	32	45	1	3 FL	1 1/4	10	26	1	20
W63 S*	56	33	65	69	10	20	32	49	1	3 FL	1 1/4	10	26	1	20
W76 S*	64	33	65	69	12	22	32	57	1	3 FL	1 1/4	10	26	1	20
W85 S*	59	39	78	82	12	22	39	47	1	4 FL	1 1/2	12	26	1 1/4	26
W90 S*	59	39	78	82	12	22	39	47	1 1/4	4 FL	1 1/2	12	26	1 1/4	26
W105 S*	65	39	78	82	12	24	39	53	1 1/4	4 FL	1 1/2	12	26	1 1/4	26
W120 S*	71	39	78	82	14	26	39	59	1 1/4	4 FL	1 1/2	12	31	1 1/4	26
W135 S*	77	39	78	82	14	28	39	65	1 1/2	4 FL	1 1/2	12	31	1 1/4	26
W150 S*	83	39	78	82	16	30	39	71	1 1/2	4 FL	1 1/2	12	31	1 1/4	26
W165 S*	89	39	78	82	16	32	39	77	1 1/2	4 FL	1 1/2	12	31	1 1/4	26
W180 S*	96	39	78	82	16	34	39	84	2	4 FL	1 1/2	12	31	1 1/4	26
W200 S*	103	39	78	82	18	37	39	91	2	4 FL	1 1/2	12	31	1 1/4	26
WA150 S*	69	46	84	88	16	29	40	53	2	6 FL ₃	2	14	31	1 1/2	34
WA165 S*	73	46	84	88	16	30	40	57	2	6 FL ₃	2	14	31	1 1/2	34
WA180 S*	79	46	84	88	16	31	40	63	2	6 FL ₃	2	14	31	1 1/2	34
WA200 S*	83	46	84	88	18	32	40	67	2	6 FL ₃	2	14	31	1 1/2	34
W225 S*	87	46	84	88	18	38	40	71	2	6 FL ₃	2	16	31	1 1/2	34
W250 S*	93	46	84	88	20	40	40	77	2	6 FL ₃	2	16	35	1 1/2	34
W275 S*	99	46	84	88	20	42	40	83	2	6 FL ₃	2	16	35	1 1/2	34
W300 S*	105	46	84	88	20	44	40	89	2	6 FL ₃	2	16	35	1 1/2	34
W325 S*	111	46	84	88	22	46	40	95	2	6 FL ₃	2	16	35	1 1/2	34
W350 S*	117	46	84	88	22	48	40	101	2 1/2	6 FL ₃	2	16	35	1 1/2	34
W375 S*	123	46	84	88	22	50	40	107	2 1/2	6 FL ₃	2	16	35	1 1/2	34
W400 S*	98	57	98	102	24	38	46	80	2 1/2	8 FL	2	16	35	2	45
W425 S*	103	57	98	102	24	38	46	85	2	8 FL	2	16	35	2	45
W450 S*	107	57	98	102	26	41	46	89	2	8 FL	2	16	35	2	45
W475 S*	111	57	98	102	26	41	46	93	2	8 FL	2	16	35	2	45
W500 S*	116	57	98	102	26	44	46	98	2	8 FL	2	16	35	2	45
W550 S*	125	67	98	102	28	47	46	107	2	8 FL	2	16	35	2	45
W600 S*	139	57	98	102	28	50	46	117	2 1/2	8 FL	2	16	35	2	45
WA650 S*	149	57	98	102	28	53	46	127	2	8 FL	2	16	35	2	45
WA700 S*	158	57	98	102	28	56	46	136	2	8 FL	2	16	35	2	45
WA750 S*	167	57	98	102	30	59	46	147	2 1/2	8 FL	2	16	35	2	45
WA400 S*	89	67	98	102	22	35	46	72	2 1/2	8 FL	2	16	35	2	56
WA450 S*	97	67	98	102	24	38	46	80	2	8 FL	2	16	35	2	56
WA500 S*	105	67	98	102	26	40	46	88	2	8 FL	2	16	35	2	56
WA550 S*	119	67	98	102	26	46	46	102	2	8 FL	2	16	35	2	56
WA600 S*	126	67	98	102	28	48	46	109	2 1/2	8 FL	2	16	35	2	56
W650 S*	134	67	98	102	28	51	46	117	2	8 FL	2	16	35	2	56
W700 S*	141	67	98	102	28	53	46	124	2	8 FL	2	16	35	2	56
W750 S*	149	67	98	102	30	56	46	132	2 1/2	8 FL	2	16	35	2	56
W840 S*	138	82	106	110	30	54	54	116	2 1/2	10 FL	2	18	42	2	69
W940 S*	150	82	106	110	32	58	54	128	2 1/2	10 FL	2	18	42	2	69
W1050 S*	162	82	106	110	34	62	54	140	3	12 FL	2	18	42	2	69
W1150 S*	174	82	106	110	36	66	54	152	3	12 FL	2	18	42	2	69
W1250 S*	186	82	106	110	36	70	54	164	3	12 FL	2	18	42	2	69

* Add **G** for natural gas or propane, **O** for #2 oil or **GO** for combination gas & #2 oil.